

PERMANENT INSTRUMENT

ACTEON 2011-pHT

New pH and temperature field transmitter

- Study, watertight, easy to install
- Widescreen graphic display : instant measurements, trend line, calibration state
- Quick and simple intuitive programming
- 4-20 mA outputs, programmable relays



Technical specifications	
pH measurement range (temperature compensated)	0,00 to 14, 00 pH
pH measurement accuracy	± 0,1 pH
Temperature measurement range	- 10,00 to + 50,00 °C
Temperature measurement accuracy (°C)	± 0,1 °C
Casing	ABS
Protection	IP 65
Operating temperature	- 25°C to + 55 °C
Dimensions (H x L x P) /Weight	173 x 195 x 103 mm / 1.5kg
Display	Widescreen back-lit graphic display : 240x128 pixels (108x58mm)
Power supply	230/115 VAC 60 Hz, Optional : 24 Vdc
Max power consumption	10 VA
4-20mA outputs	2 galvanic isolation outputs (max load 700ohms)
Relay outputs	2 relays that can be configured in 2 different modes : - Adjustment in alarm mode (1pH and 1 temperature threshold) - Adjustment in regulation mode (2 pH threshold with 2 relays)

Simple, sturdy and reliable like its legendary predecessor, the APF series, with additional digital intelligence and leading-edge technology.

Fields of application :

- Wastewater treatment, (input/output controls, aeration and anoxic tanks, odour control unit);
- Industrial effluent treatment (waste controls; neutralisation);
- Drinking water (raw water control, water treatment, output control);
- Surface water monitoring, etc.

PH and Temperature Sensors

The standard version of the device is supplied with a gel-filled electrode sensor for ensuring stable measurements and durability. Special sensors (solid electrolyte, charged filling, etc.) are used for taking measurements in difficult areas (very low conductivity or hardness).



Gel-filled electrode pH sensor:

- pH/Reference combined electrode
- pH: Special glass electrode
- Reference: Ag/AgCl gelled electrolyte
- Electrolyte: Gelled KCL (Plastogel)
- Dimensions: Diameter 20.5mm x Length 144mm
- Weight: 440g
- Watertight: IP68
- Cable length: 10m standard length
- (other lengths available on request)
- Length of glass section: 65mm
- Working range: 0-14pH. Insensitive to Na⁺ ions up to pH13
- Temperature of use: 0 - 60°C when submerged
- Submersion: cable seal is watertight when submerged
- Pressure resistance : 5 bars

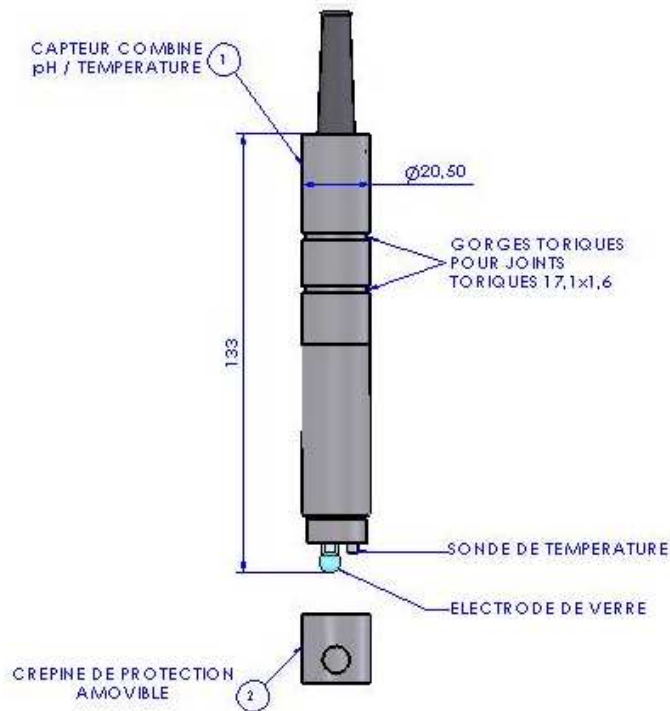

Accessories for electronic unit installation :

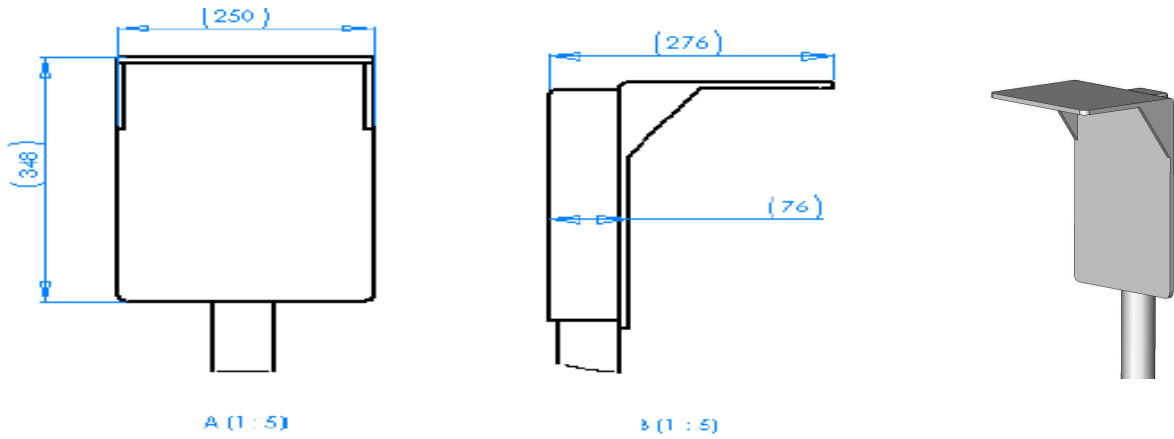

Accessories for sensor installation in tanks and open canals :

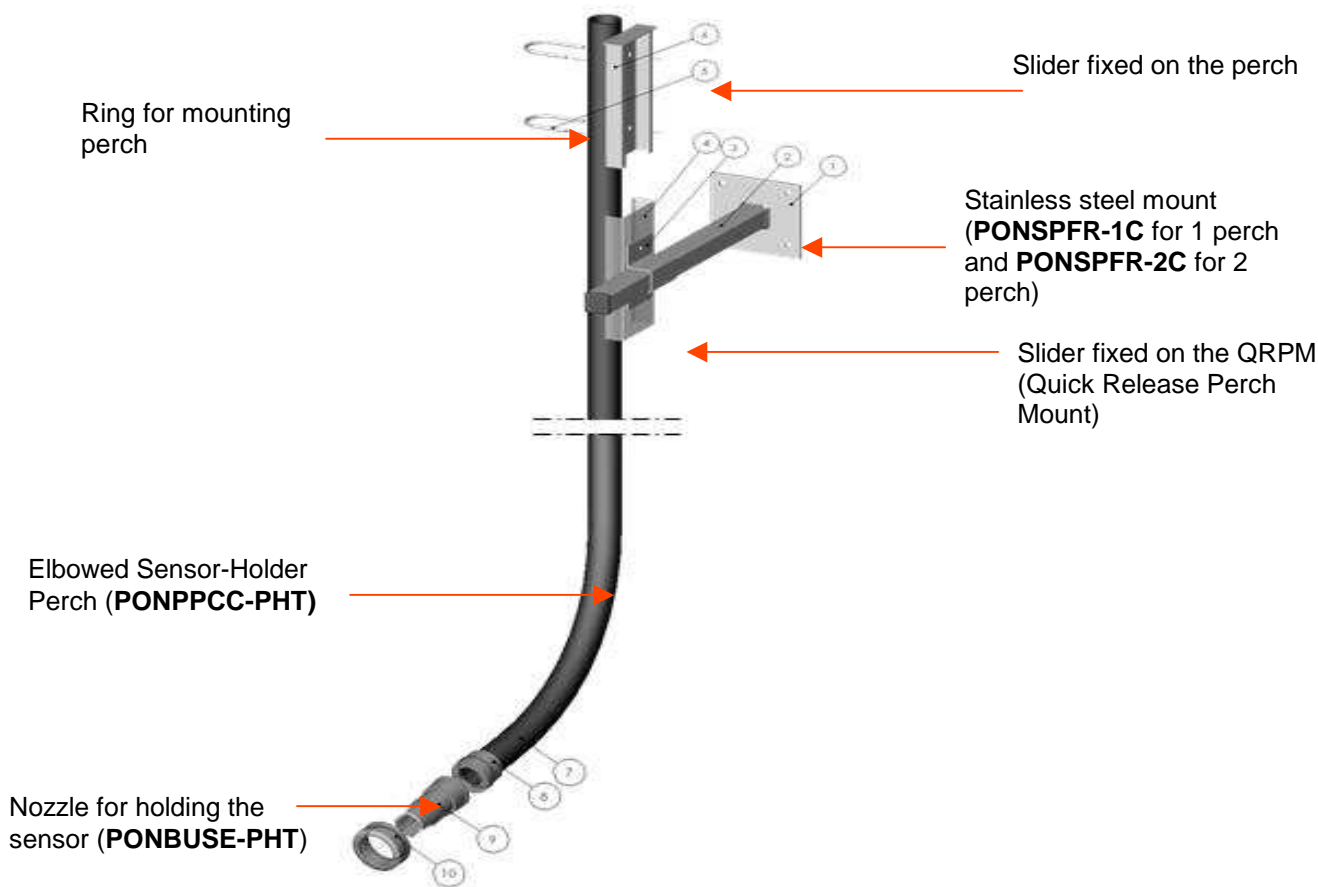

Accessories for sensor installation in pipes :

